

DH152/DR152

General Features

The model DH152 or DR152 grinder pump station is a complete unit that includes: two grinder pumps, check valve, HDPE (high density polyethylene) tank, controls, and alarm panel. A single DH152 or DR152 is ideal for up to four, average single-family homes and can also be used for up to 12 average single-family homes where codes allow and with consent of the factory.

- Rated for flows of 3000 gpd (11,356 lpd)
- 150 gallons (568 liters) of capacity
- Indoor or outdoor installation
- Standard outdoor heights range from 93 inches to 160 inches

The DH152 is the “hardwired,” or “wired,” model where a cable connects the motor controls to the level controls through watertight penetrations.

The DR152 is the “radio frequency identification” (RFID), or “wireless,” model that uses wireless technology to communicate between the level controls and the motor controls.

Operational Information

Motor

1 hp, 1,725 rpm, high torque, capacitor start, thermally protected, 120/240V, 60 Hz, 1 phase

Inlet Connections

4-inch inlet grommet standard for DWV pipe. Other inlet configurations available from the factory.

Discharge Connections

Pump discharge terminates in 1.25-inch NPT female thread. Can easily be adapted to 1.25-inch PVC pipe or any other material required by local codes.

Discharge

15 gpm at 0 psig (0.95 lps at 0 m)
11 gpm at 40 psig (0.69 lps at 28 m)
7.8 gpm at 80 psig (0.49 lps at 56 m)

Accessories

E/One requires that the Uni-Lateral, E/One’s own stainless steel check valve, be installed between the grinder pump station and the street main for added protection against backflow.

Alarm panels are available with a variety of options, from basic monitoring to advanced notice of service requirements.

The Remote Sentry is ideal for installations where the alarm panel may be hidden from view.

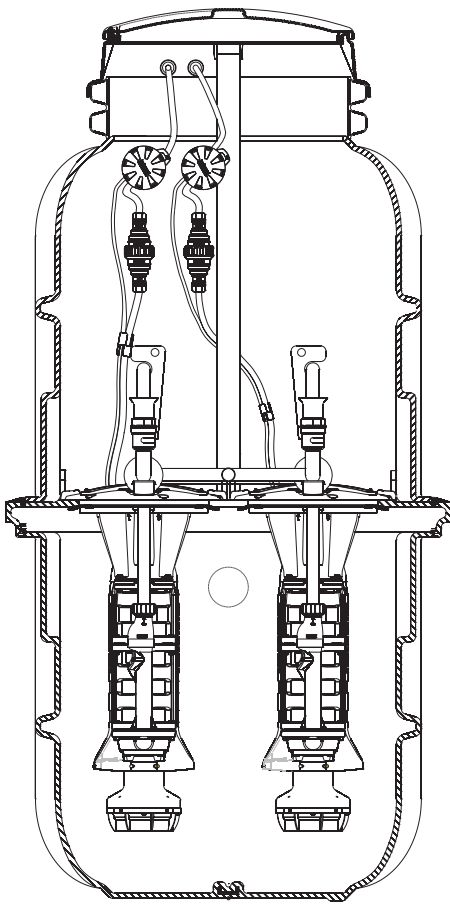

Patent Numbers: 5,752,315
5,562,254 5,439,180